

701, 700A Series

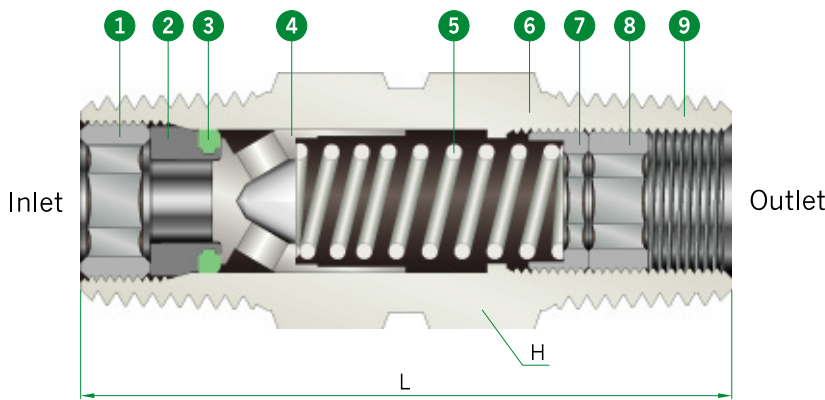

* 701 Series is without Adjusting screw and locking screw

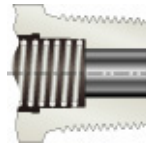

- 1 Stop nut**
 - helps to contain the insert.
- 2 Insert**
 - prevents blow-out of o-ring.
- 3 O-Ring**
 - provides leak tight shut-off
- 4 Back Stopped Poppet**
 - prevents the spring from being over stressed
- 5 Spring**
 - a wide range of adjustable springs are available for the cracking pressure in the range from 3psig to 600psig.
- 6 One-piece Body**
 - made from bar stock
- 7 Adjusting screw (700A Series Only)**
 - sets desired cracking pressure
- 8 Locking screw (700A Series Only)**
 - maintains setting.
- 9 End Connections**
 - Male & Female ISO tapered threads, Male & Female NPT.

Technical Data

Series	701	700A
Max. Working Pressure		3000 psig (206bar)
Operating Temperature Range	FKM : -10°F to 375°F (-23°C to 191°C) NBR : -10°F to 250°F (-23°C to 121°C)	
Nominal Cracking Pressure	1/3, 1, 3, 5, 10, 25 psig	3 to 50 psig 50 to 150 psig 150 to 350 psig 350 to 600 psig

Table of Dimensions

Basic Part No.	Flow Dia.	End Connections		Dimensions				
		Inlet	Outlet	L		H		
				mm	in.	mm	in.	
Stationary Cracking Pressure								
CV (701 Series)	-M4N	4.8	1/4" Male NPT	1/4" Male NPT	41.1	1.62	14.2	9/16
	-M8N	10.0	1/2" Male NPT	1/2" Male NPT	57.9	2.28	22.2	7/8
	-F4N	4.8	1/4" Female NPT	1/4" Female NPT	61.2	2.41	19.1	3/4
	-F8N	10.0	1/2" Female NPT	1/2" Female NPT	94.2	3.71	26.9	1 1/16
	-FM4N	4.8	1/4" Female NPT	1/4" Male NPT	58.2	2.29	19.1	3/4
	-MF4N		1/4" Male NPT	1/4" Female NPT	44.4	1.75		
-MF8N	10.0	1/2" Male NPT	1/2" Female NPT	71.9	2.83	26.9	1 1/16	
Adjustable Cracking Pressure								
CVA (700A Series)	-M4N	4.8	1/4" Male NPT	1/4" Male NPT	41.1	1.62	14.2	9/16
	-M4R		1/4" Male ISO Tapered	1/4" Male ISO Tapered				
	-F4N		1/4" Female NPT	1/4" Female NPT				
	-M8N	10.0	1/2" Male NPT	1/2" Male NPT	65.0	2.55	22.2	7/8
	-M8R		1/2" Male ISO Tapered	1/2" Male ISO Tapered				

All dimensions in millimeters. Dimensions are for reference only, subject to change.

Cracking Pressure Adjustment

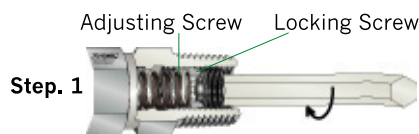

Step. 1 Insert the hex wrench into the lock screw. Loosen the lock screw by rotating the hex wrench 2 to 3 full turns in the counterclockwise direction.



Step. 2 After loosening the lock screw, align the hex wrench as it will enter into the adjustment screw. To establish the desired cracking pressure, rotate the hex wrench in a clockwise direction to increase the cracking pressure or rotate the hex wrench in a counterclockwise direction to decrease the cracking pressure.



Step. 3 After adjusting the adjustment screw to reach the desired cracking pressure, withdraw the hex wrench from the adjustment screw. Tighten the lock screw against the adjustment screw firmly by rotating the hex wrench in a clockwise direction.

After testing for the desired cracking pressure, if additional adjusting is required, repeat steps 1 through 3.

Materials of Construction

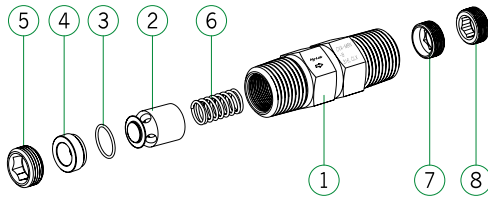

No.	Component	Valve Body Materials		
		316 Stainless Steel	Brass	
			Material Grade / ASTM Specification	
1	Body ^①	TP316 / A479 or A276	Brass	
2	Poppet	TP316 / A479 or A276	Brass	
3	O-ring ^②	FKM	NBR	
4	Insert	TP316 / A479 or A276	Brass	
5	Stop nut	TP316 / A479 or A276	Brass	
6	Spring	SS302 / A313		
7	Adjusting screw ^{③†}	TP316 / A479 or A276	TP316 / A479 or A276	Brass ^③
8	Locking screw ^{③†}			

① Silicone-based lubricant.
 ② Molybdenum disulfide-based dry film lubricant.
 ③ Adjusting screw in brass valve with "C" or "D" (150~600 psig) spring is 316SS.
 † 700A Series only.

Cracking and Reseal Pressure at 70°F (20°C)

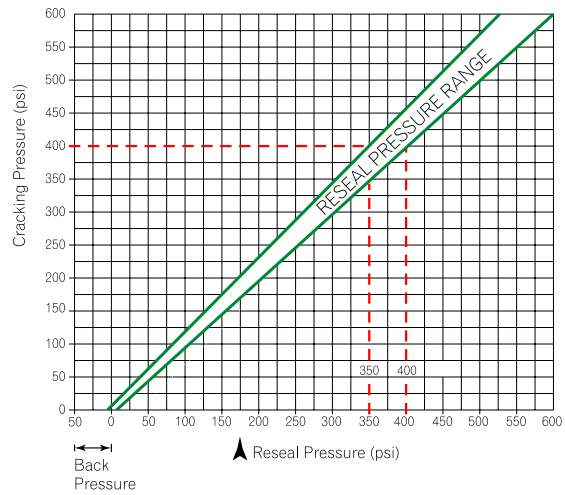

Example : For a valve set to crack at 400 psi, the minimum reseal pressure would be 350psi.

! Valves that are not actuated for a period of time may crack initially at higher than subsequent cracking pressure.

- 701, 700A series check valves set to crack at 20psi or lower may require back pressure to reseal bubble-tight.
1. Cracking pressure : The upstream pressure at which the first indication of flow occurs.
 2. Reseal pressure : The upstream pressure at which there is no indication of flow.

Flow Rate at 70°F (20°C)

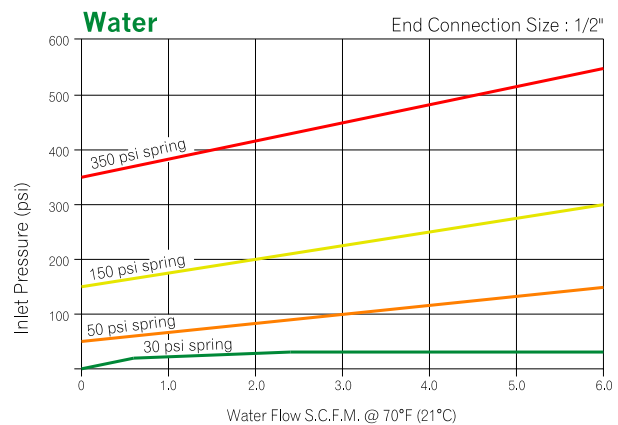
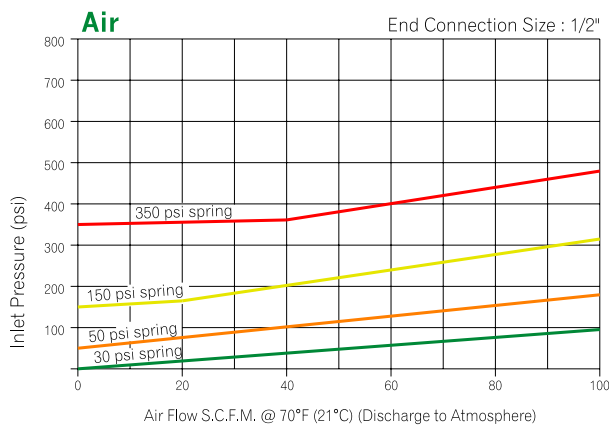
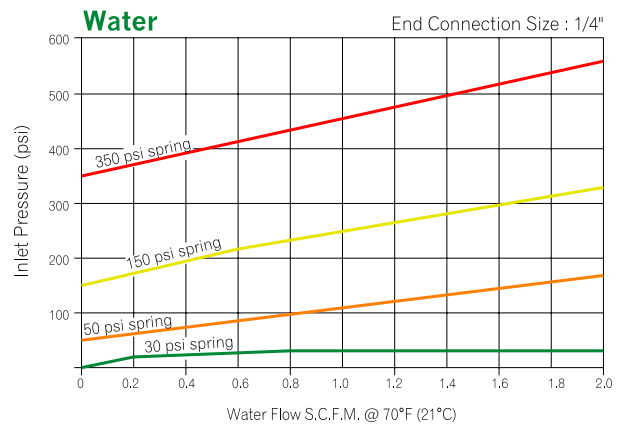
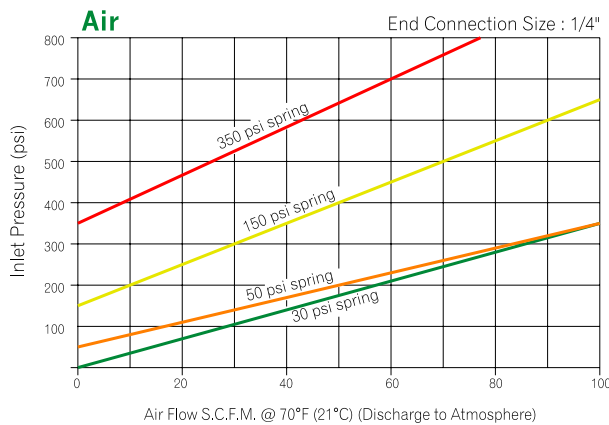

Check Valves

Cleaning

- Each valve is cleaned and packaged according to the company standard cleaning procedures.

Testing

- Each valve is tested with nitrogen for cracking and reseal performance.
- Optional tests are available upon request.

O - Ring Materials

- Available are various O - ring materials, whose temperature ratings are shown below.

Material	Temperature Rating
FKM	-23°C to 191°C (-10°F to 375°F)
NBR	-23°C to 121°C (-10°F to 250°F)
FFKM (Kalrez®)	-23°C to 315°C (-10°F to 600°F)
PTFE	-46°C to 232°C (-50°F to 450°F)
Neoprene	-40°C to 121°C (-40°F to 250°F)
Ethylene Propylene	-46°C to 149°C (-50°F to 300°F)

* High back pressure is required for PTFE to seal leak - tight.

Ordering Information

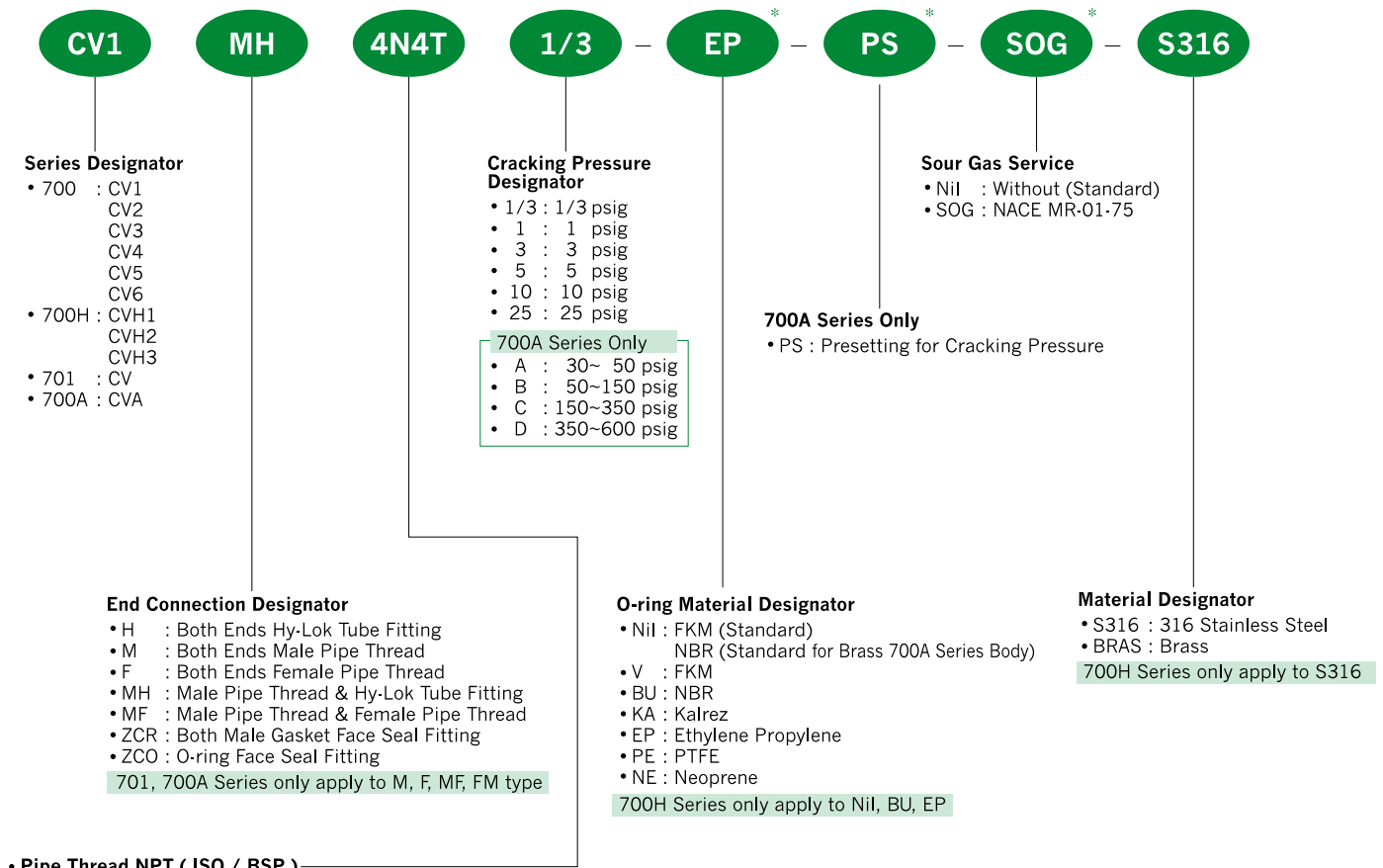

• Pipe Thread NPT (ISO / BSP)

Thread(NPS)	1/8	1/4	3/8	1/2	3/4	1
Designator	2N(R)	4N(R)	6N(R)	8N(R)	12N(R)	16N(R)

• Tube

Fractional Tube	O.D.	1/8"	1/4"	3/8"	1/2"	3/4"	1"
	Designator	2T	4T	6T	8T	12T	16T
Metric Tube	O.D.	3mm	6mm	10mm	12mm	20mm	25mm
	Designator	3M	6M	10M	12M	20M	25M

Note * : No designator is required for standard.
e.g CVH1H - 4T - 1/3 - S316

701, 700A Series only apply to 1/2" & 1/4"

SAFETY in VALVE SELECTION

Proper installation, materials compatibility, operation and maintenance of these valves are the responsibility of the user. The total system design must be taken into consideration to ensure optimal performance and safety.