

# Line pressure regulator LE53-6

spectro**cem**

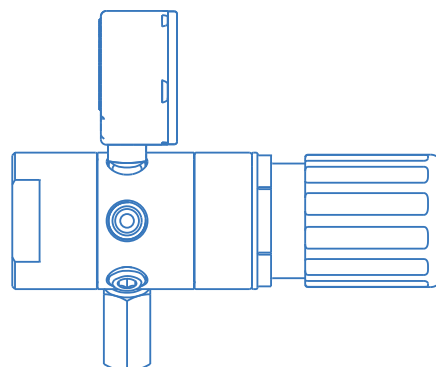

Line pressure regulator LE53-6



## Product features

- Double-stage stainless steel line pressure regulator with very stable outlet pressure and anti-vibration device
- For corrosive, toxic gases and gas mixtures with corrosive components up to quality 6.0
- 6 ports for flexible and individual configuration
- Central filter
- Suitable for inlet pressures up to 300 bar
- Max. outlet pressures 1,5 up to 200 bar
- Suitable for ECD-applications
- Pressure regulator can be evacuated
- Approved for use with oxygen
- Simple outlet pressure limitation by handwheel
- New laboratory-style design
- Easy to install

## Technical data

<b>Type</b>	double-stage
<b>Inlet pressure <math>P_1</math></b>	max. 300 bar
<b>Outlet pressure <math>P_2</math></b>	1,5 / 4 / 10 / 20 bar
<b>Materials</b>	
Body regulator and relief valve:	SS 316L (SS 1.4404)
Valve seat:	PVDF
Diaphragm:	Hastelloy C276
Filter:	Sintered SS 316L
<b>In- and outlets</b>	1/4" NPT-F
<b>Temperature range</b>	-30°C to +60°C
<b>Leak rate (to atmosphere)</b> (via seat)	1x10 <sup>-8</sup> mbar l/s He 1x10 <sup>-6</sup> mbar l/s He
<b>Flow capacity</b>	$C_v=0.15$
<b>Weight</b>	1.7 kg

## Flow curves LE53

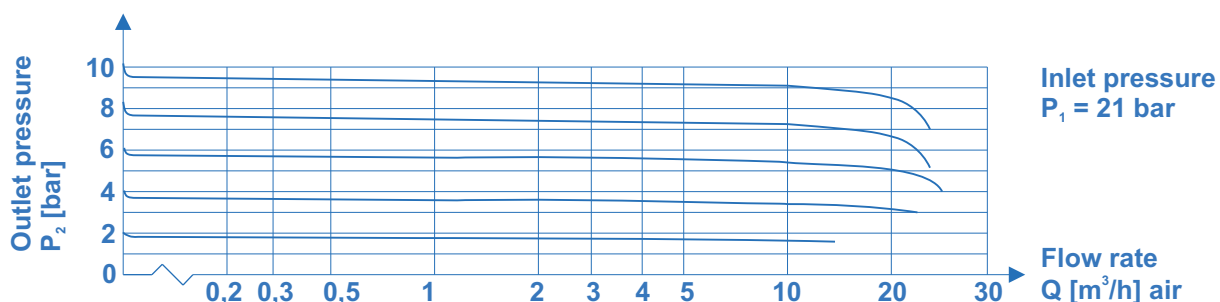

# Line pressure regulator LE53-6



## Dimensions

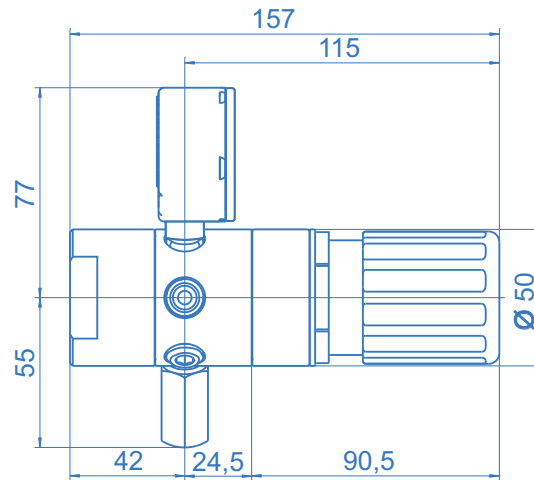
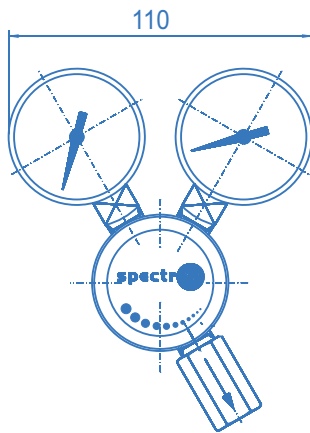

## Ordering information:

Panel pressure regulator LE53-6

### In- / outlets

- CE 1/4 - 1/8" / 1/4" / 1/2" - OD compression fitting (stainless steel)
- CE 6 - 3/6/8/10/12 mm OD compression fitting (stainless steel)
- B - plug
- A - relief valve - 1/4"-18 NPT-F ( $P_2 \leq 100$  bar)
- K - contact pressure gauge
- M - pressure gauge
- 0 - 1/4"-NPT-F (port only)

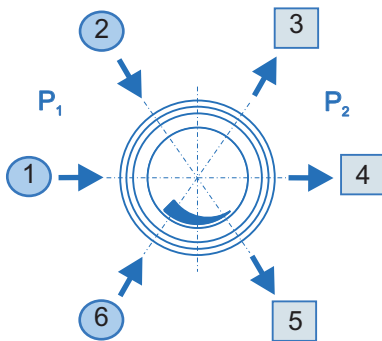

Inlet left: **L**

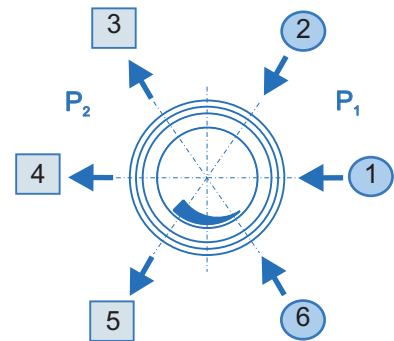

Inlet right: **R**

LE53 - L - 300 - 20 - 1 - 2 - 3 - 4 - 5 - 6 - N2

### Inlet

- L - left
- R - right

### Inlet pressure $P_1$

- 100 - max. 100 bar
- 200 - max. 200 bar
- 300 - max. 300 bar

### Outlet pressure $P_2$

- 1,5 - bis 1,5 bar
- 4 - bis 4 bar
- 10 - bis 10 bar
- 20 - bis 20 bar

### Type of gas

Please specify type of gas (for selection of valve seat materials)

For inlet pressure up to 50 bar and outlet pressure of max. 1,5 or 4 bar please use E51