

Gage / Root Valve

Gage Valves GV

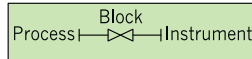

Part No.	End Connection		Dimensions				Weight (kg/lb)
	Process	Instrument	L	L ₂	H	S	
GV ** MF8N	Male NPT 1/2"	Female NPT 1/2"	90 (3.54)	87.0(3.43)	50 (1.97)	32(1.26)	0.6/1.3
GV ** MF12N8N	Male NPT 3/4"	Female NPT 1/2"		104.5(4.11)		35(1.38)	0.7/1.5
GV ** MF8N12N	Male NPT 1/2"	Female NPT 3/4"	84(3.3)	87.0(3.43)	32(1.26)	35(1.38)	0.7/1.5
GV ** F8N	Female NPT 1/2"	Female NPT 1/2"				32(1.26)	0.7/1.5

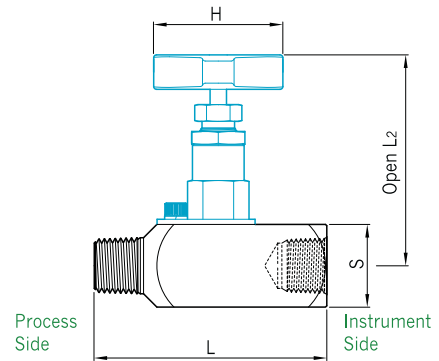

Root Valves GRV

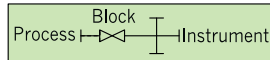

Part No.	End Connection		Dimensions				Weight (kg/lb)
	Process	Instrument	L	L ₂	H	S	
GRV** MF8N	Male NPT 1/2"	Female NPT 1/2"	136 (5.35)	87.0(3.43)	50 (1.97)	32(1.26)	0.9 / 2.0
GRV** MF12N8N	Male NPT 3/4"	Female NPT 1/2"		104.5(4.11)		35(1.38)	1.0 / 2.2
GRV** MF8N12N	Male NPT 1/2"	Female NPT 3/4"	102(4.02)	87.0(3.43)	32(1.26)	35(1.38)	1.0 / 2.2
GRV ** F8N	Female NPT 1/2"	Female NPT 1/2"				32(1.26)	0.8 / 1.8

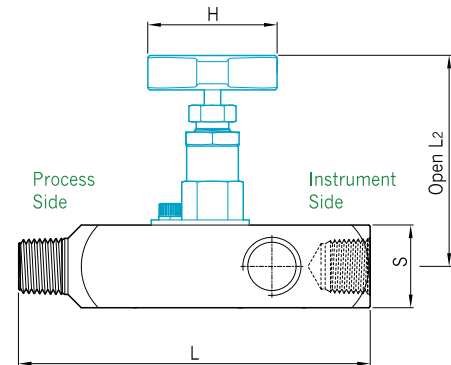

Gage 2-Valves GV2 ** - MF8N

1.2 kg (2.6 lb)

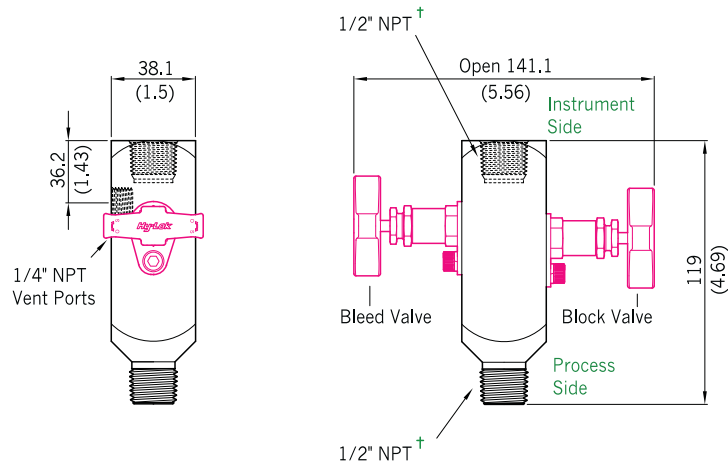
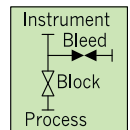

Note : "+" available in other size upon request.