

SAE J 518 C 61/62 Flanges

SAE - socket weld flange

SAAFS - SW

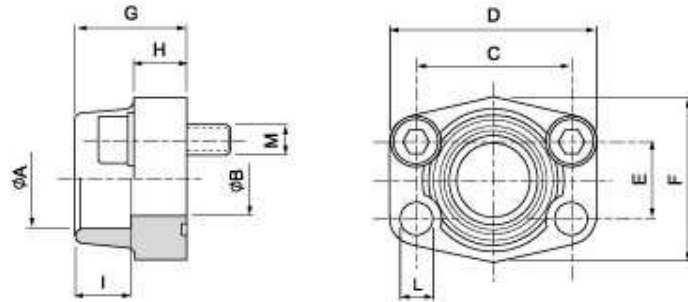

Maximum recommended working pressure kg/cm ²	Nominal flange size, in	Type	Dimensions										Screws		Weight kg
			A	B	C	D	E	F	G	H	I	L	M		
			metr.		unc										
Standard Pressure															
350	½"	SAAFS 308-08 SW	21.6	13	38.10	54	17.48	46	36	16	19	9.0	M 8 x 30	⅜ x 1¼	0.25
350	¾"	SAAFS 312-12 SW	27.2	19	47.63	65	22.23	50	36	18	19	11.0	M 10 x 35	⅜ x 1½	0.39
350	1"	SAAFS 316-16 SW	34.0	25	52.37	70	26.19	55	38	18	19	11.0	M 10 x 35	⅜ x 1½	0.46
280	1½"	SAAFS 320-20 SW	42.8	32	58.72	79	30.18	68	41	21	22	11.5	M 10 x 40	⅜ x 1½	0.66
210	1½"	SAAFS 324-24 SW	48.6	38	69.85	93	35.71	78	45	25	24	13.5	M 12 x 45	½ x 1¾	1.05
210	2"	SAAFS 332-32 SW	61.0	51	77.77	102	42.88	90	45	25	26	13.5	M 12 x 45	½ x 1¾	1.19
175	2½"	SAAFS 340-40 SW	73.5	63	88.90	114	50.80	105	50	25	30	13.5	M 12 x 45	½ x 1¾	1.40
140	3"	SAAFS 348-48 SW	90.5	76	106.38	134	61.93	124	50	27	34	17.0	M 16 x 50	⅝ x 2	2.15
35	3½"	SAAFS 356-56 SW	103.0	89	120.65	152	69.85	136	48	27	34	17.0	M 16 x 50	⅝ x 2	2.40
35	4"	SAAFS 364-64 SW	115.0	102	130.18	162	77.77	146	48	27	34	17.0	M 16 x 50	⅝ x 2	2.85
High Pressure															
420	½"	SAAFS 608-08 SW	21.6	13	40.49	54	18.24	46	36	16	19	9.0	M 8 x 30	⅜ x 1¼	0.26
420	¾"	SAAFS 612-12 SW	27.2	19	50.80	71	23.80	55	35	21	22	11.0	M 10 x 35	⅜ x 1½	0.50
420	1"	SAAFS 616-16 SW	34.0	25	57.15	81	27.76	65	42	25	22	12.5	M 12 x 45	⅜ x 1¾	0.76
420	1½"	SAAFS 620-20 SW	42.8	32	66.68	95	31.75	78	45	27	25	14.5	M 14 x 45	½ x 1¾	1.20
420	1½"	SAAFS 624-24 SW	48.6	38	79.38	112	36.50	94	50	30	8	17.0	M 16 x 50	⅝ x 2	1.65
420	2"	SAAFS 632-32 SW	61.0	51	96.82	134	44.45	114	65	37	24	21.0	M 20 x 65	⅝ x 2½	2.45
420	2½"	SAAFS 640-40 SW	73.5	63	123.80	180	58.70	152	80	45	30	26.0	M 24 x 75	-	8.30