

SAE J 518 C 61/62 Flanges

SAE - socket weld flange 500 psi - companion

SAGFC - SW

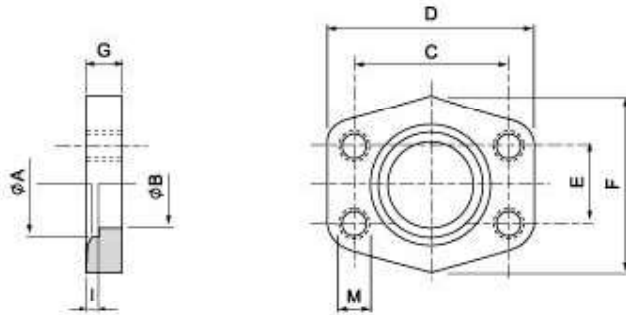

Maximum recommended working pressure kg/cm ²	Nominal flange size, in	Type	Nominal pipe size	Dimensions								Screws M	Weight kg
				A	B	C	D	E	F	G	I		
		Standard Pressure											
40	½"	SAGFC 08 SW	21.3 x 3.7	21.6	13	38.10	56	17.48	46	10	3	M 8	0.12
40	¾"	SAGFC 12 SW	26.7 x 3.9	27.2	19	47.63	65	22.23	50	12	4	M 10	0.20
40	1"	SAGFC 16 SW	33.4 x 4.5	34.0	25	52.37	70	26.19	55	12	4	M 10	0.25
40	1½"	SAGFC 20 SW	42.2 x 4.9	42.8	32	58.72	79	30.18	68	12	4	M 10	0.31
40	1½"	SAGFC 24 SW	48.3 x 5.1	48.6	38	69.85	93	35.71	78	15	4	M 12	0.50
40	2"	SAGFC 32 SW	60.3 x 5.5	61.0	51	77.77	102	42.88	90	15	4	M 12	0.59
40	2½"	SAGFC 40 SW	73.0 x 7.0	73.5	63	88.90	114	50.80	105	15	4	M 12	0.72
40	3"	SAGFC 48 SW	88.9 x 7.6	90.5	76	106.38	134	61.93	124	20	5	M 16	1.25
40	3½"	SAGFC 56 SW	101.5 x 8.1	103.0	89	120.65	152	69.85	136	20	5	M 16	1.50
40	4"	SAGFC 64 SW	114.3 x 8.6	115.0	102	130.18	162	77.77	146	25	6	M 16	2.15
40	5"	SAGFC 80 SW	141.3 x 9.5	143.0	127	152.40	190	92.08	170	28	8	M 16	3.00